



## Flexel Ecofloor Cable Mat

### Installation instructions

Please read these notes carefully and follow the instruction guidelines shown in this booklet as they will ensure optimum, safe performance and may also affect the validity of the guarantee provided. If in any doubt consult your supplier or the manufacturer.

Planning the installation.

- 1). Measuring up.
- 2). Table sizing guide.
- 3). Control Options.
- 4). Planning the Installation.
- 5). 'Add On' cables for larger areas.
- 6). Floor preparation.
- 7). Marking out.
- 8). Laying the Cable Mat.
- 9). Install Thermostat and Floor probe.
- 10). Tiling the floor.
- 11). Finished Floor Diagram.
- 12). Final testing.
- 13). Switching on.

### **1). Measuring up.**

It is important to measure the room correctly and avoid all permanent fixtures such as baths, showers, kitchen and bedroom units, (remember also that it is important to avoid thermally blocking the heated area as this will result in localised heat build up and possible subsequent damage to the floor covering).

Allowing for perimeter clearance deduct a further 5% to reach the actual available heated floor area.

## **2). Table Sizing Guide**

### **Description:**

Thin profile, double insulated and earth braided, twin conductor cable attached to an open weave matting at standard 160 W/m<sup>2</sup> output. Calculate usable floor area as for cable kits and select nearest size down. (Return feed to the thermostat is NOT required as cable is twin core).

### **Twin Core Cable**

Type	Output	Surface output	Width	Length	Area /m <sup>2</sup>	Resistance
	(W)	(W / m <sup>2</sup> )	(m)	(m)	(m <sup>2</sup> )	(Ω)
12210-165	210	160	0.5	2.60	1.30	252
12260-165	260	160	0.5	3.20	1.65	203
12340-165	340	160	0.5	4.20	2.10	156
12410-165	410	160	0.5	5.20	2.60	129
12500-165	500	160	0.5	6.10	3.00	106
12560-165	560	160	0.5	6.70	3.90	94
12670-165	670	160	0.5	8.30	4.20	79
12810-165	810	160	0.5	10.20	5.10	65
121000-165	1000	160	0.5	12.30	6.10	53
121210-165	1210	160	0.5	15.10	7.60	44
121400-165	1400	160	0.5	17.60	8.80	38
122150-165	2150	160	0.5	26.60	13.30	25

## **3). Control options:**

(Available separately from Flexel International Ltd.)

### **Type 132AF**

16amp programmable/thermostat fitted with dual floor and air sensing sensors. Functions include optimum start, 4 daily programmes with separate day, night and holiday settings.

### **Type:EB100**

12amp electronic multifunction thermostat allowing optional floor or air temperature sensing.

### **Type:RTR 3521**

10amp mechanical air temperature thermostat.

### **Type RTR 6121**

As 3521 with min/max temperature locking.

### **Type RTR 3545**

10amp tamperproof air sensing thermostat suitable for installation in bathrooms.

#### **4). Planning the Installation.**

All cable incorporates an earth screen to allow installation into wet areas. The diagram (figure 1) shows a kitchen that is just under 5m x 3.5m. The total usable area is however 14 m<sup>2</sup>. Take off 5% of this figure to allow for perimeter clearance. Total heating area is 13.3m<sup>2</sup> - requires cable mat 122150 165.

This example also highlights the advantage of the Flexel Ecofloor twin conductor heating cable, requiring connection to the electricity supply at one end only thereby removing the need to design the layout to get the cable back to the termination point. (If in doubt and on receipt of a marked and scaled drawing your supplier will calculate the appropriate mat size required).

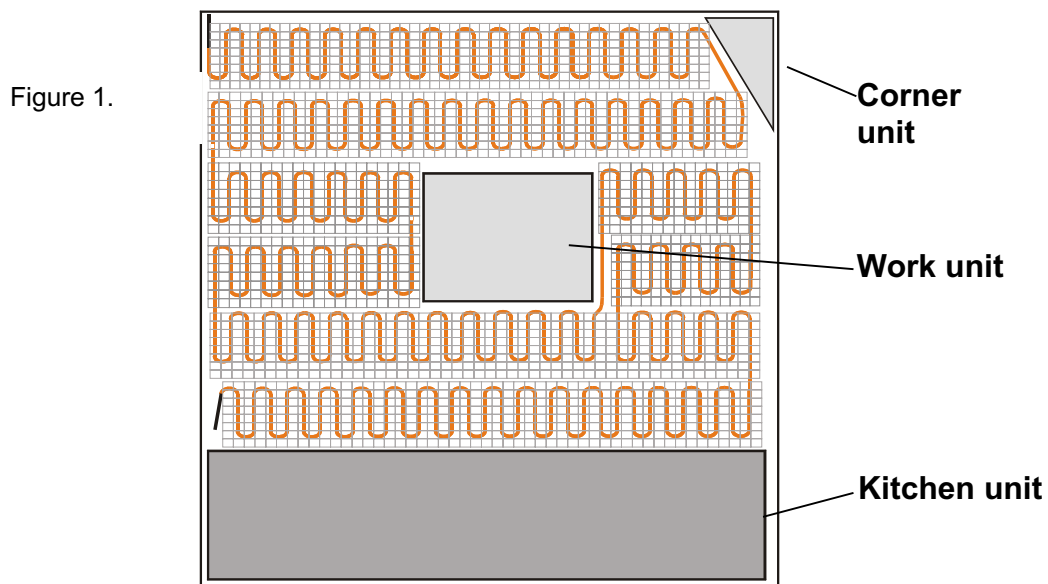

## 5). Installation of larger areas requiring 'add-on' cables.

Illustrated is a 20 square metre conservatory requiring a 12 2150 (165) cable mat and 12 670 (165) cable mat to provide optimum heat. (17.5m<sup>2</sup> coverage allowing for edge clearance).

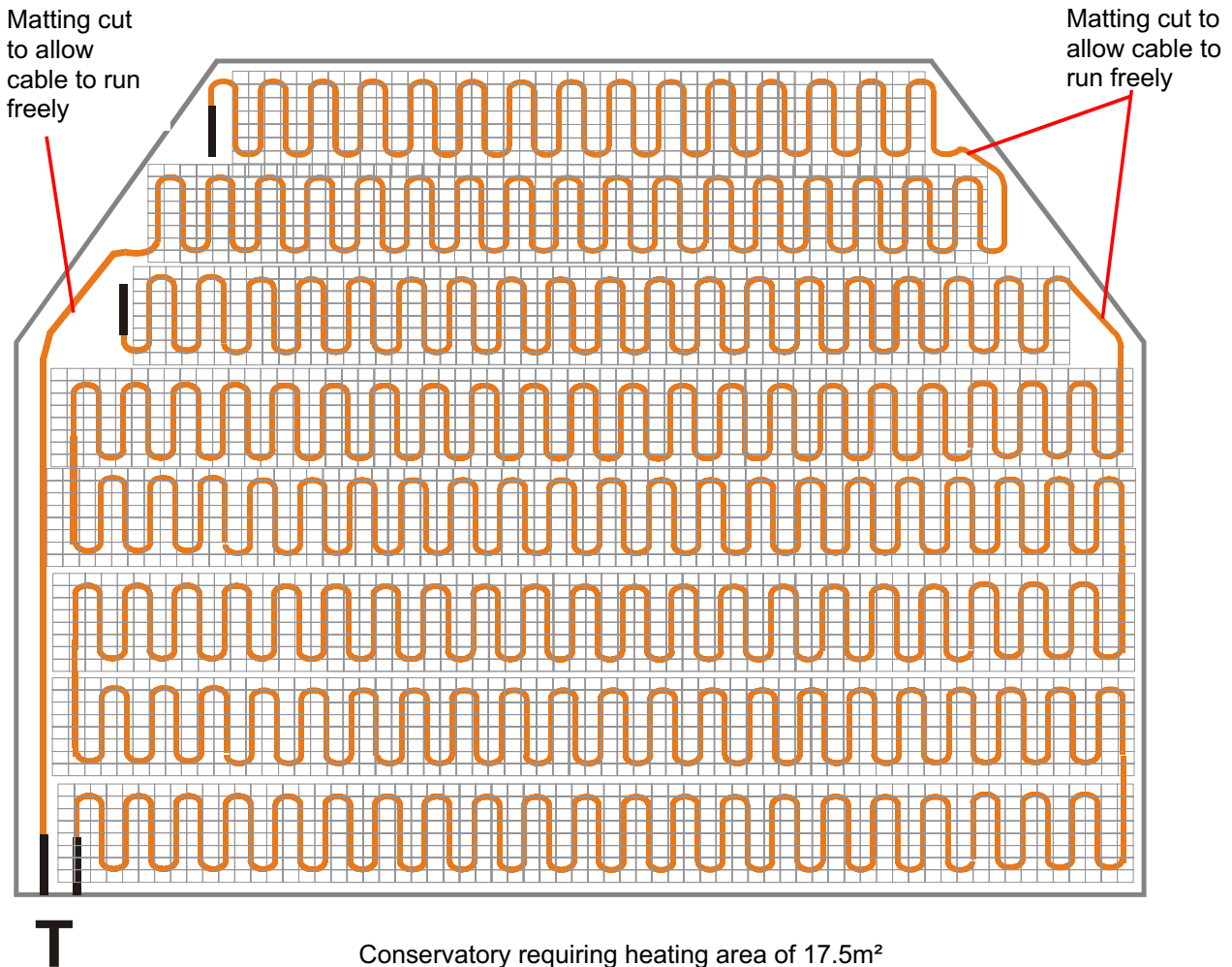

(Installation is explained below but first prepare and mark out the floor as described in sections 6 and 7, cut mat as shown in section 8).

Using the main cable mat of 2150 watts (13.3m<sup>2</sup>) run this out from the termination point to the opposite end of the room. Check that remaining floor area will accommodate the additional 670 watt cable (4.2m<sup>2</sup> coverage). Lay the additional cable mat and, where necessary, cut the matting to allow the cable to be run around objects or previously laid matting.

**Remember to never overlap the mats.**

The thermostat sensor must be positioned centrally between cable loops.

## **6). Floor preparation.**

Cable mats can be laid onto most existing floor surfaces that are sound and suitably prepared. Any existing floor coverings such as carpet or vinyl must be removed. Bitumastic sealant should, be covered with a floor-levelling screed.

### **Primer.**

When installing the mat over concrete, wooden or existing tiled floors refer to the manufacturers standard guidelines.

### **Concrete floor.**

New concrete floors must be allowed time to cure naturally. This will depend on weather conditions but normally 1 week per 25mm is taken as a guideline. Existing concrete floors must be clean and level and where necessary a self-levelling screed (latex compound) should be applied ahead of the cable installation.

### **Timber floor.**

Existing timber floors must be clean, sound and level. To achieve this it may be necessary to have a screw fixed overlayment of WBP (weather and boil proof) plywood or marine board.

### **Insulation.**

To ensure optimum performance and minimise running costs floor insulation such as Aquapanel Thermal, Marmox or Wedi Board should be laid directly under the heating cable.

Having determined the size of the area to be heated, the heat level required and the electrical supply position form a channel in the floor adjacent to this point as illustrated.

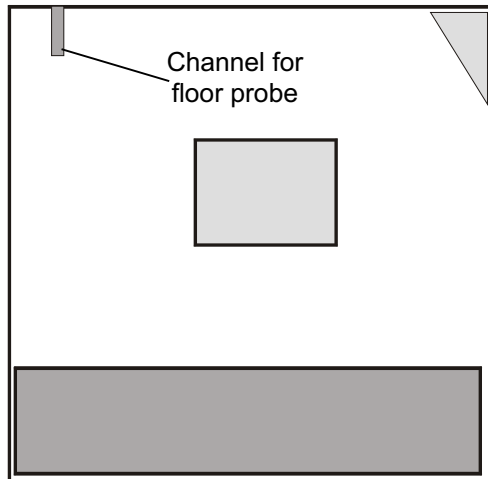

**Figure 2.**

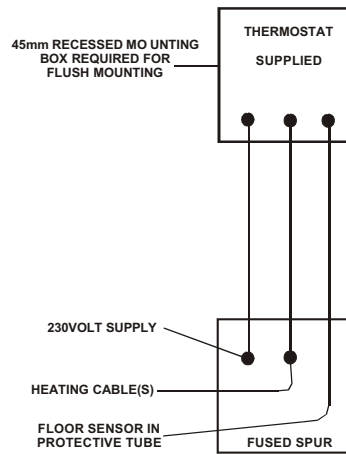

**Figure 3.**

The cables should be no closer than 50mm from the walls and any other fixed obstructions.

Final connection and testing should be carried out by a qualified electrician but prior to this stage a thermostat and supply provision should be made as shown in figure 3.

**8). Laying the cable mat**

Connection is only required at one end for twin conductor cable mats. The first 3 metres is black cable that can be cut as required. The orange cable is the heated part that must never be cut or shortened.

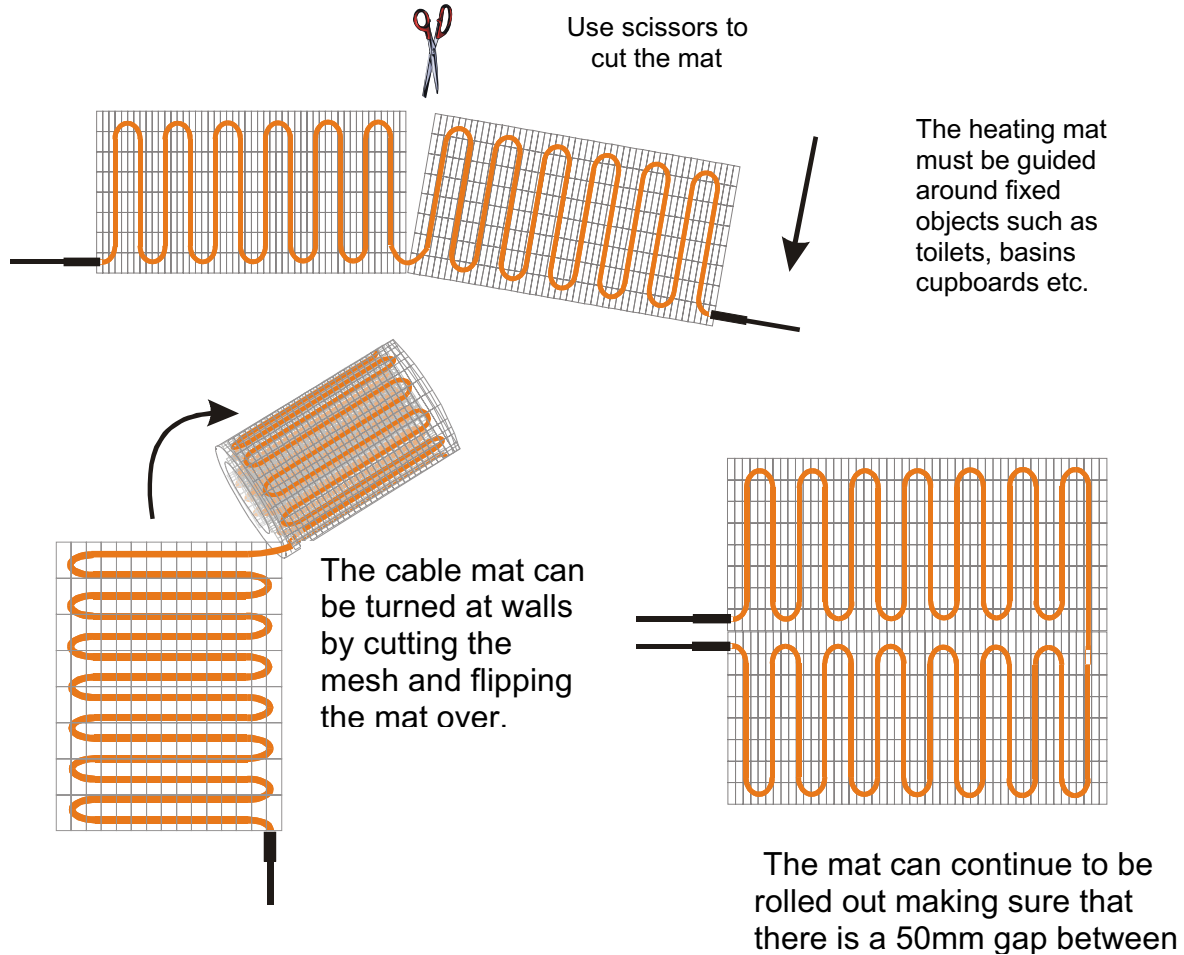

Never bury or try to hide the cable. If necessary, start again.

If you have ordered the wrong size of mat contact your supplier.

***Now and referring to the tables on page 2 test the cable circuit for continuity (resistance) using an ohm meter. Avoid traffic over the laid area until floor tiling is complete.***

### **9). Install the Thermostat and Floor Probe.**

Follow the instructions provided with the thermostat and the floor probe. For the floor probe you will need to cut a channel for the protective spiral hose. (This may have been done at an earlier stage as suggested). Fix the hose into position and shorten to the required length. Feed the floor probe into the hose and block off the end. The floor probe is then attached to the thermostat.

The thermostat should be installed in the room that is to be heated. For bathrooms the thermostat must be placed outside the bathroom and as close to the installation as possible. If necessary however, the heating cable cold tail and thermostat can be extended by up to 50 metres using cable supplied by Flexel International Limited.

### **10). Tiling the floor.**

Once the cables are laid suitable protection boards / old carpet must be provided to avoid damage during tiling. Tile adhesive can be laid in either a single or a two layer operation depending on the tiler's preference to accommodate the 3mm cable thickness. The adhesive must be laid evenly in the same direction as the cables are running making sure there are no air spaces.

***The table of products on page 11 are suitable for use with a Flexel Ecofloor underfloor heating system. Refer to the additional requirements when using Depron underlay insulation and for further information and advice contact the Flexel technical department.***

### **11). Finished Floor Diagrams.**

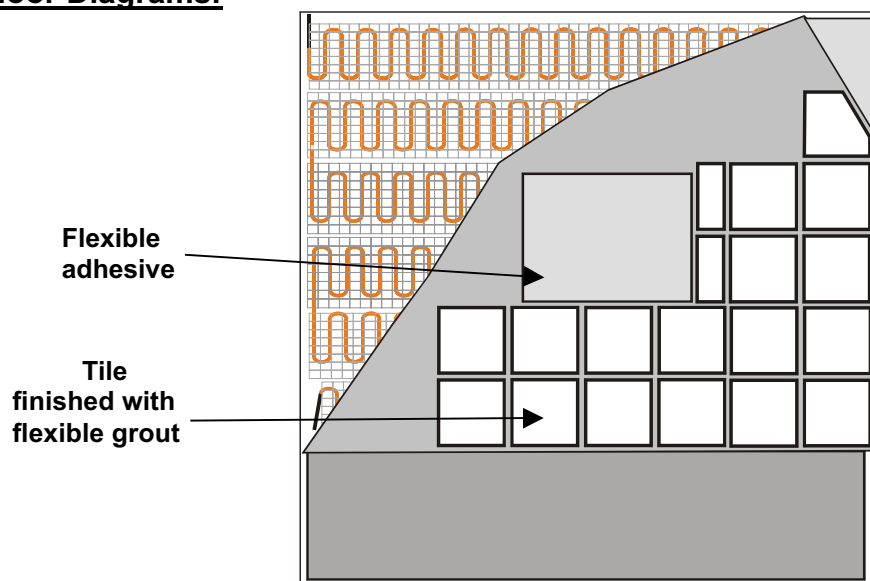

## Concrete Floor

### Cementitious Backed Insulation

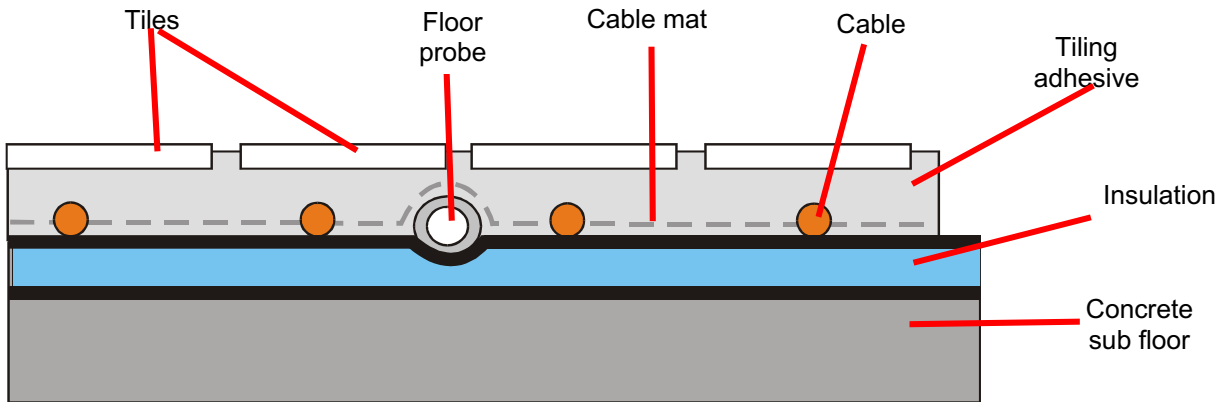

## Timber Floor

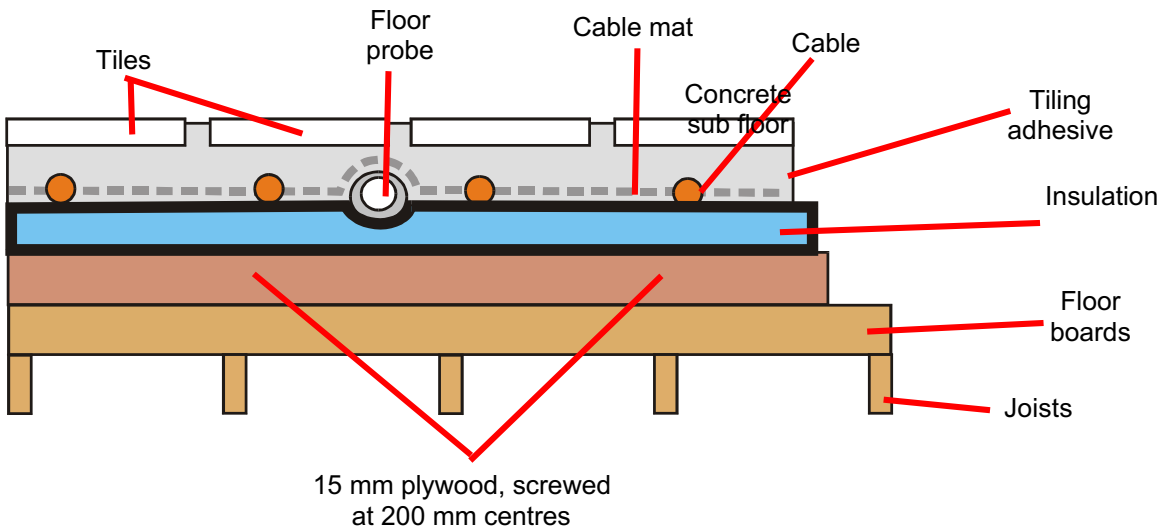

## 12). Final testing.

The electrician should test the continuity of the floor sensor (already fitted) and retest the connected resistance of each cable. A further insulation test should be carried out in accordance with IEE regulations. The electrician should affix a suitable advisory warning label at the electricity distribution board and complete the attached certificate which must be retained and serve as part of the guarantee requirement.

## 13). Switching on.

Before switching on the underfloor heating allow a minimum of 3 days for natural drying of the tile adhesive and grout. Initially operate the system for 2-3 hours per day increasing to full continuous operation after 6-7 days.

General guidelines for preparation of subfloors and UK manufacturers adhesive products suitable for use in conjunction with Flexel Ecofloor undertile heating cables and cable mats. (To be read in conjunction with the installation instructions supplied)

Manufacturer	Surface	Primer	Tile Adhesive	Grout
<b>Ardex</b>	Concrete Timber	No primer required Ardion 82 primer	Ardu-Flex 500 Ardurit S16 + Ardion 90 admix	Arduflex-FL
<b>Bal</b>	New Concrete  Existing concrete  Timber	No primer required on a sound surface. Use a slurry bonding coat if unsound Slurry bonding coat 2 parts portland cement 1 part Bal-Bond SBR Bal Bond SBR.	Bal-Rapidset Flexible  Bal-Rapidset Flexible rapid Bal-Rapidset Flexible	Bal Flexgrout  Bal Flexgrout Bal Flexgrout
<b>Howtex</b>	Concrete & Timber	Howtex universal primer	Howtex single part Flexible rapid	Howtex-ceramic widejoint flexigrout
<b>Mapei</b>	Timber	Mapeprim SP primer	Ultraplan-self levelling compound over cable, then Kerabond with Asolastic flexible additive/Granirapid.	Mapei Ultracolor Polmer modified grout
<b>Mira</b>	Concrete      Timber	Mira 7110 base cleaner   Mira 4800 antifire fluid primer. Use Mira 4120 and 4440 multicoat for wet areas.  Mira 4800 antifire fluid primer	Mira X-Plan self Levelling acrylic and Fibre reinforced levelling compound. Mira 3250 superplan Fix acrylic reinforced cement based quick curing tile adhesive mira 3600 multcrete highly elastic two part adhesive.	Mira mastic Mira mastic
<b>Nicobond</b>	Concrete   Timber	1 pt Nicobond primer to 4 pt water or 1 pt Nicobond primer to 1 pt water if porous. 1pt Nicobond primer to 1 pt water	Nicobond fast floor and wall adhesive Nicobond fast floor and wall adhesive + Nicobond 2002.	Nicobond tilers grout + Nicobond enhancer 2002 Nicobond tilers Grout + Nicobond enhancer 2002
<b>PCI</b>	Concrete   Timber	No primer required.   No primer required	Fliebspachtel 15 self levelling compound, then any flexible cement based adhesive Timberflex or Sontex Woodflex with Sontex RS2.	Any flexible grout. Groutflast. Sontex grey grout and Grout Admix.
<b>RMC Biscem</b>	Concrete & Timber	No primer required.	Bissem fast set adhesive with Flexibond additive	Bisgrout Floor Grouting
<b>Sovereign</b>	Concrete   Timber	If unsound use 50:50 SBR bonding agent and warter.  SBR bonding agent	Sovereign Quick Fix tile adhesive  Sovereign Quick Fix tile adhesive	Sovereign water resistant tile grout.  Sovereign grey tile Grout with 1 part SBR-3 parts water

**Note: Ensure tile adhesive has no air spaces. Dab fixing of tiles should be avoided**

For further technical information and advice contact:  
Flexel International Ltd. - Queensway Industrial Estate - Glenrothes - Fife - KY7 5QF  
Tel: 01592 757313 Fax: 01592 754535 Email: info@flexel.co.uk Web: www.flexel.co.uk